

注文番号 ORDER No.	御注文先 CUSTOMER	工事番号 WORK No.	件名 JOB SITE
-------------------	------------------	------------------	----------------

改訂番号 REV. No.	年月日 DATE	内容 REMARKS	承認 APP'D	作成 MADE
------------------	-------------	---------------	-------------	------------

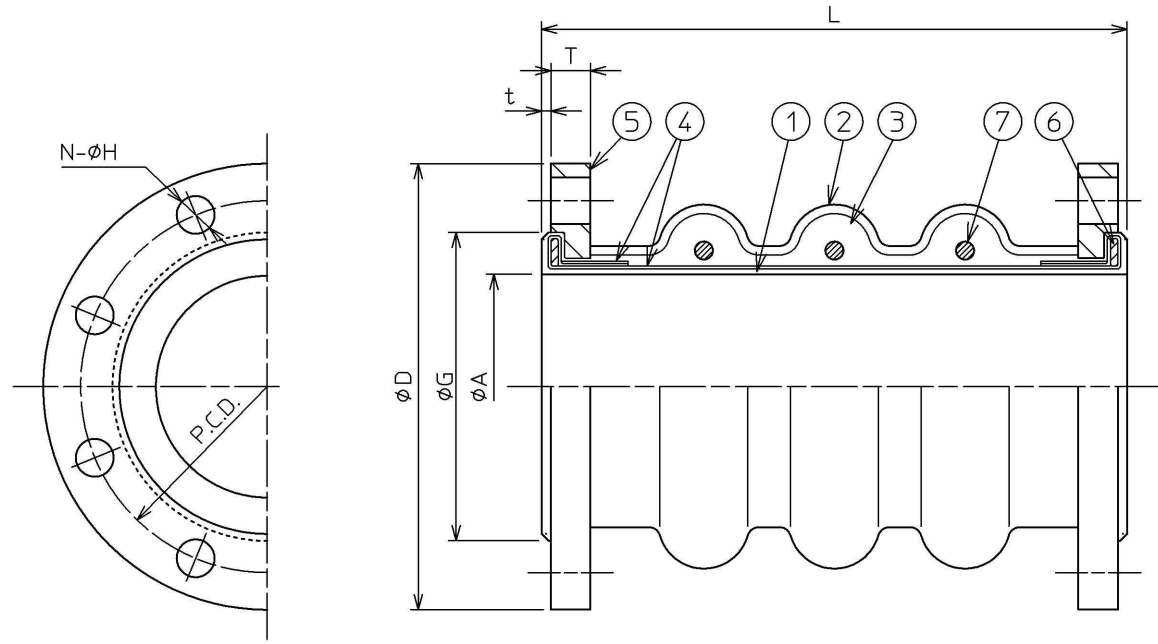

* (地上用) フランジが SS400 の場合は
溶融亜鉛メッキとなります。
Hot dip galvanizing is applied
for carbon steel flange. (For the ground)

* (埋設用) フランジが SS400 の場合は溶融亜鉛メッキ
+ エポキシ樹脂塗装 (2 回塗り) となります。
Hot dip galvanizing and Epoxy resin painting
is applied for carbon steel flange. (For laying underground)

7	補強リング REINFORCEMENT RING	CARBON STEEL	3	
6	ソリッドリング SOLID RING	CARBON STEEL	2	
5	* フランジ FLANGE	CARBON STEEL	2	JIS10KF
4	補強繊維 REINFORCEMENT FIBER	SYNTHETIC FIBER	1	
3	埋めゴム PLUGED RUBBER	SYNTHETIC RUBBER	1	
2	外貼ゴム OUTER LAYER RUBBER	SYNTHETIC RUBBER	1	
1	内貼ゴム INNER LAYER RUBBER	SYNTHETIC RUBBER	1	
品番 ITEM	部品名称 NAME	材質 MATERIALS	数量 Q'TY.	備考 REMARKS

各許容変位量は同時には適用できません。同時に考慮する場合は別途御相談下さい。
Each allowable movement figure is not effect at same time. If you consider applying more than two figure at same time, please consult us.

口径 SIZE	本体 BODY			フランジ FLANGE				許容圧縮量 ALLOWABLE COMPRESSION (mm)	許容伸張量 ALLOWABLE ELONGATION (mm)	許容偏心量 ALLOWABLE LATERAL MOVEMENT (mm)	設計圧力 DESIGN PRESS. (MPa)	仕様 SPECIFICATIONS			全長 L	数量 Q'TY.	
	内径 φA	座径 φG	厚さ t	規格 RATING	外径 φD	ピッチ PCD	厚さ T					数-径 N-φH	流体 FLUID	温度 (°C)			圧力 (MPa)
20 ^A	3/4 ^B	20	50	3	JIS10K	100	75	14	4-15	22	18	100	0.98			350L	
25	1	25	60	3	JIS10K	125	90	14	4-19	22	18	100	0.98			350L	
32	1 1/4	32	72	3	JIS10K	135	100	16	4-19	22	18	100	0.98			350L	
40	1 1/2	40	77	3	JIS10K	140	105	16	4-19	22	18	100	0.98			350L	
50	2	50	87	3	JIS10K	155	120	16	4-19	22	18	100	0.98			350L	
65	2 1/2	65	112	3	JIS10K	175	140	18	4-19	22	18	100	0.98			350L	
80	3	75	123	3	JIS10K	185	150	18	8-19	22	18	100	0.98			350L	
100	4	100	143	3	JIS10K	210	175	18	8-19	30	27	100	0.98			350L	
125	5	125	178	4	JIS10K	250	210	20	8-23	30	27	100	0.98			350L	
150	6	150	208	4	JIS10K	280	240	22	8-23	30	36	100	0.98			500L	
200	8	200	254	5	JIS10K	330	290	22	12-23	30	36	100	0.98			500L	
250	10	250	319	6	JIS10K	400	355	24	12-25	37	45	100	0.98			500L	
300 ^A	12 ^B	300	364	6	JIS10K	445	400	24	16-25	37	45	100	0.98			550L	

名称
TITLE **ZRJ-MK100F**
JIS10KF
(LAY UNDERGROUND)

製作数量
QUANTITY

作成年月日
DATE 2011/08/17

図面番号
DRAWING No. NM1FOA-0-HP



尺度
SCALE

承認
APP'D

審査
CHECKED

作成
MADE

担当
CHARGE

not   

 **ゼンシン** 株式会社
ZENSHIN CO., LTD JAPAN