

# Z-18000

Big compression and extension with outer pipe

外筒型

●用途

使用目的:軸方向の伸縮吸収

構造:ベローズの外側に保護管を取り付けた構造。

●特長

伸縮時には内筒と外筒に沿ってベローズがスムーズに作動し、座屈が防止できます。

●フランジ規格

JIS5K、JIS10K、JIS20K、JPI

複式タイプも製作可能

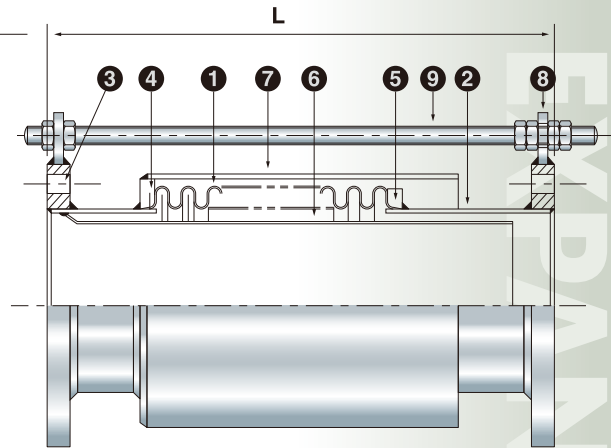
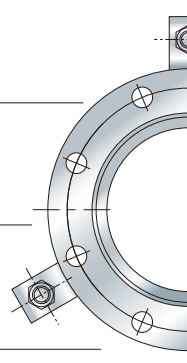
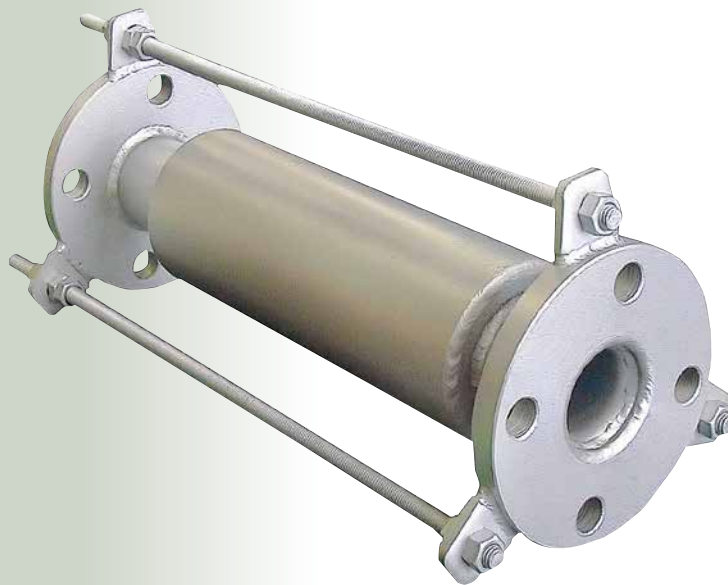

番号 No	部品名称 Name	材質 Material
1	ベローズ Bellows	SUS304 Stainless steel 304
2	端管 Pipe	SGP Carbon steel
3	フランジ Flange	SS400 Carbon steel
4	リング Ring	SS400 Carbon steel
5	リング Ring	SS400 Carbon steel
6	内筒 Inner pipe	SUS304 Stainless steel 304
7	外筒 Outer pipe	SGP Carbon steel
8	ホルダー Holder	SS400 Carbon steel
9	タイロッドボルト Tie-rod bolt	SS400 Carbon steel

※ベローズ、金具素材の変更も可能です

※Other materials are also available on request.

●ベローズ寸法表／常温、0.1MPa

口径 Size (A)	山高 Height	ピッチ Pitch	厚さ Thickness	伸縮量 Axial movement	山数 No. of convolution	面間 Length
50	10	10	0.6	±5	6	250
				10	12	320
				15	17	380
				20	23	450
65	15	15	0.6	±8	4	270
				14	7	320
				20	10	370
				28	14	470
80	15	15	0.8	±5	4	270
				10	7	320
				15	10	370
				20	14	470
100	20	20	1	±5	3	270
				10	5	320
				15	8	380
				20	10	470
125	30	30	1.2	±10	3	320
				15	4	370
				20	5	420
				25	7	470
150	30	30	1.2	±10	3	320
				15	4	370
				20	5	420
				25	7	470
200	30	30	1.2	±10	3	320
				15	4	370
				20	5	420
				25	7	470
250	30	30	1.2	±10	3	350
				15	4	400
				20	5	450
				25	7	500
300	30	30	1.2	±10	3	350
				15	4	400
				20	5	450
				25	7	500

●Applications

**Purpose**

Absorption of axial expansion and contraction.

**Structure**

Composing protection tubes at outer sides of bellows.

●Features

The bellows move smoothly along the inner tube and outer tube when it is expanded or contracted so as to prevent buckling.

●Flange Rating

JIS,JPI,BS,DIN also available.

Double type is also available

EMERSON JOINTS Z-18000